

TRANSPORTNI UREĐAJI

VJEŽBE - 04

asistent: Matija Hoić, mag. ing. mech.

ZADATAK 7 (3)

Za vježbu....

Ležajevi užetnika su valjni. Kolika je iskoristivost tog koloturnika pri dizanju tereta? Koliki su dodatni otpori vožnje uslijed otpora gibanju užeta kroz koloturnik?

$$\eta_r = \frac{F_{1,te}}{F_1} = \frac{\frac{Q}{i_{kol}}}{\frac{Q}{\eta_0(1+\eta_0+\eta_0^3+\eta_0^5)}} = \frac{\eta_0(1+\eta_0+\eta_0^3+\eta_0^5)}{i_{kol}}$$

$$\Delta F = F_1 - F_8 = F_1 - F_1 \cdot \eta_0^7 = F_1 \cdot (1 - \eta_0^7) = \frac{Q \cdot (1 - \eta_0^7)}{\eta_0 + \eta_0^2 + \eta_0^4 + \eta_0^6}$$

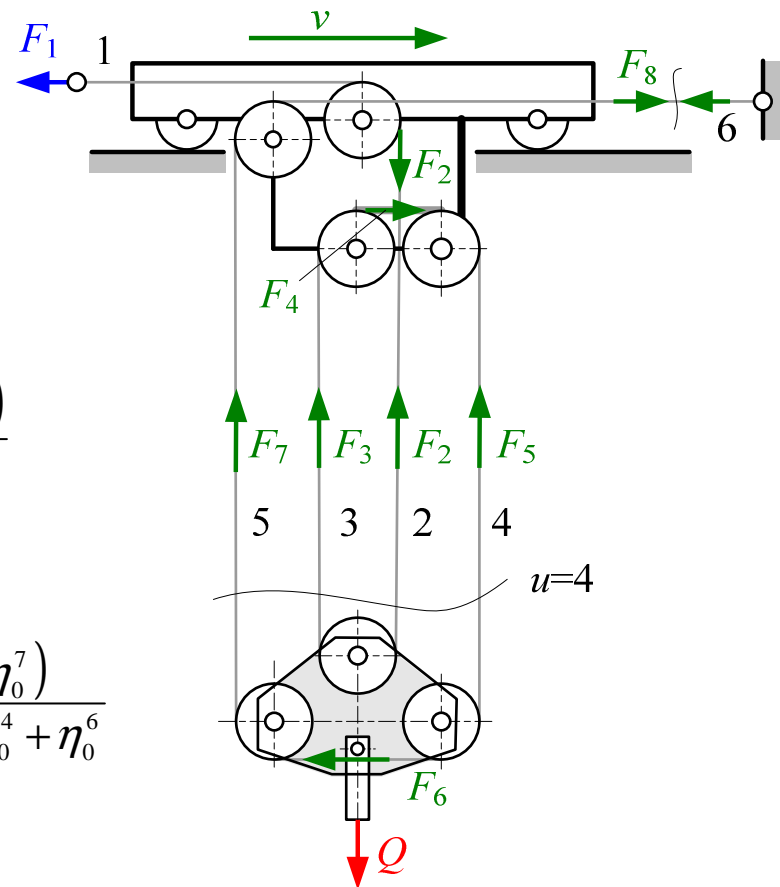

ZADATAK 8 (1)

Za mehanizam vožnje vitla mosne dizalice zadano je:

$P = 1,5 \text{ kW}$ - snaga pogonskog motora, $Q_t = 25 \text{ t}$ - nosivost, $m_v = 5 \text{ t}$ - masa vitla, $n_{EM} = 975$ - brzina vrtnje motora, $J_{EM} = 0,0325 \text{ kgm}^2$ - moment inercije rotora motora, $J_S = 0,06 \text{ kgm}^2$ - moment inercije spojke, $D_k = 350 \text{ mm}$ - promjer kotača, $v_v = 20 \text{ m/min}$ - brzina vožnje, $\eta_{red} = 0,90$ - stupanj djelovanja reduktora mehanizma za vožnju, $f_e = 10 \text{ N/kN}$ - specifični otpori vožnje, $t_p = 3 \text{ s}$ - vrijeme ubrzanja, $s = 10 \text{ m}$ - duljina vožnje vitla.

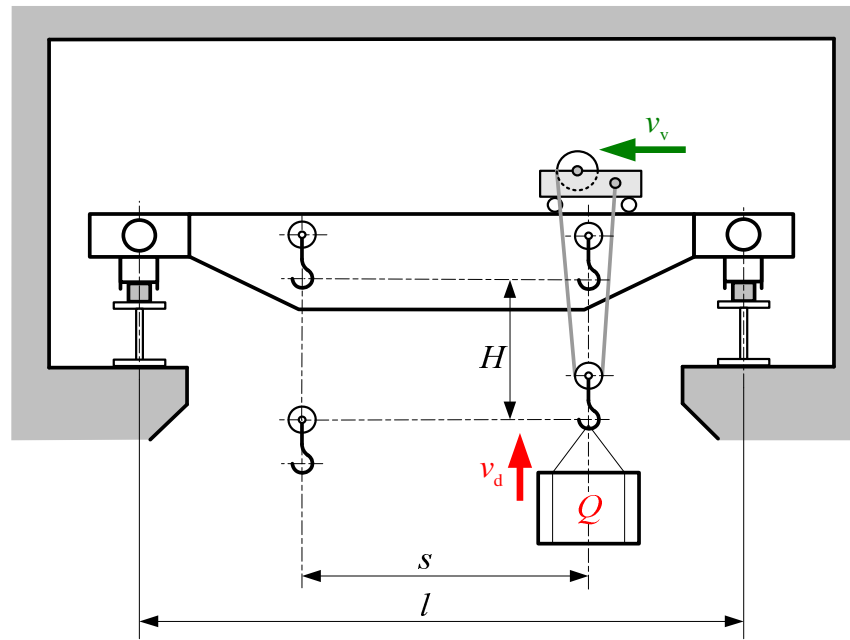

ZADATAK 8 (2)

Izračunati:

- Prijenosni odnos reduktora
- Provjeriti instaliranu snagu motora pri ustaljenoj vožnji.
- Provjeriti snagu motora pri pokretanju, ako je .

$$M_p = 1,8M_n$$

- Izračunati graničnu brzinu mosta

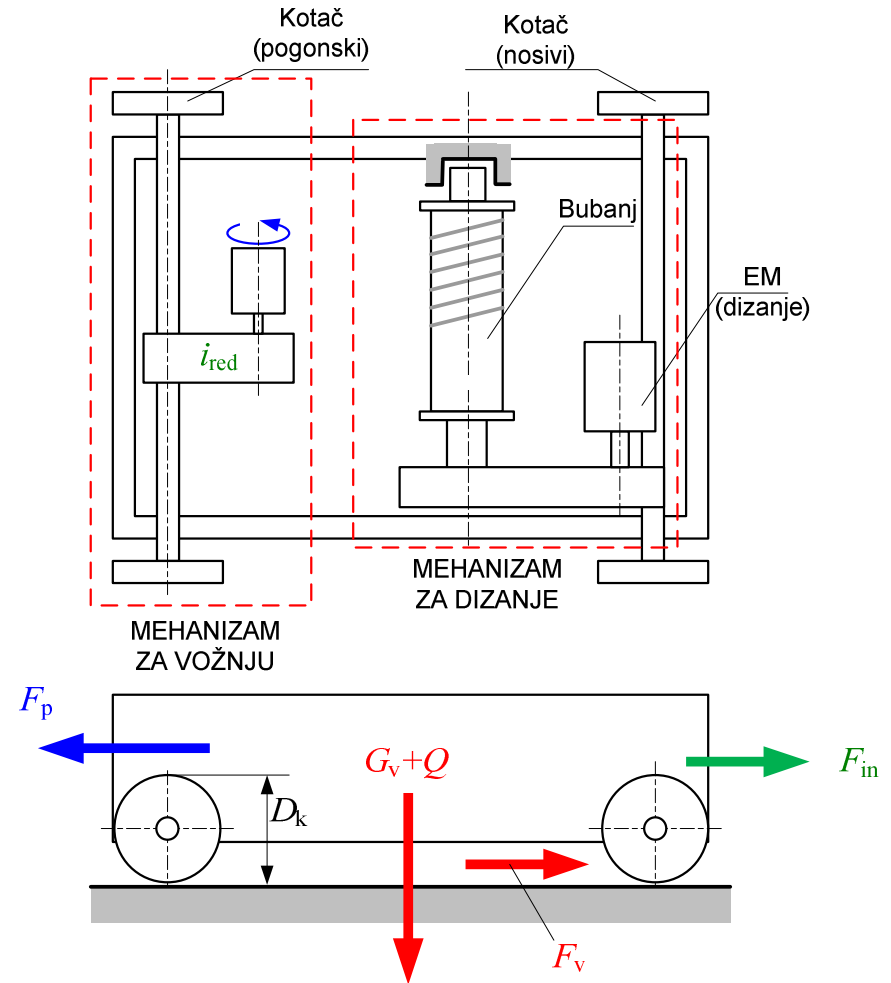

ZADATAK 8 (3)

a) Prijenosni odnos reduktora

$$i_{\text{red}} = \frac{n_{\text{EM}}}{n_{\text{k}}} = \frac{n_{\text{EM}}}{2\pi \cdot \omega_{\text{k}}} = \frac{n_{\text{EM}}}{2\pi \cdot \frac{v_{\text{v}}}{D_{\text{k}}/2}} = \frac{\pi \cdot D_{\text{k}} \cdot n_{\text{EM}}}{v} = \frac{\pi \cdot 0,35 \cdot \frac{1000}{60}}{\frac{20}{60}} = 54,97 \approx 55$$

b) Provjeriti instaliranu snagu motora pri ustaljenoj vožnji.

$$P_{\text{st}} = \frac{F_{\text{v}} \cdot v}{\eta_{\text{uk}}} \qquad F_{\text{v}} = (G_{\text{vit}} + Q) \cdot f_{\text{e}}$$

$$P_{\text{st}} = \frac{(Q_{\text{t}} + m_{\text{v}}) g \cdot f_{\text{e}} \cdot v_{\text{v}}}{\eta_{\text{uk}}} = \frac{(25 + 5) \cdot 9,81 \cdot 10 \cdot 20}{0,9 \cdot 60} = 1090 \text{ W}$$



ZADATAK 8 (4)

c) Provjeriti snagu motora pri pokretanju, ako je $M_p = 1,8M_n$

Mogućnost kratkotrajnog preopterećenja asinkronog elektromotora

$$M_p = 1,7 \dots 2M_n$$

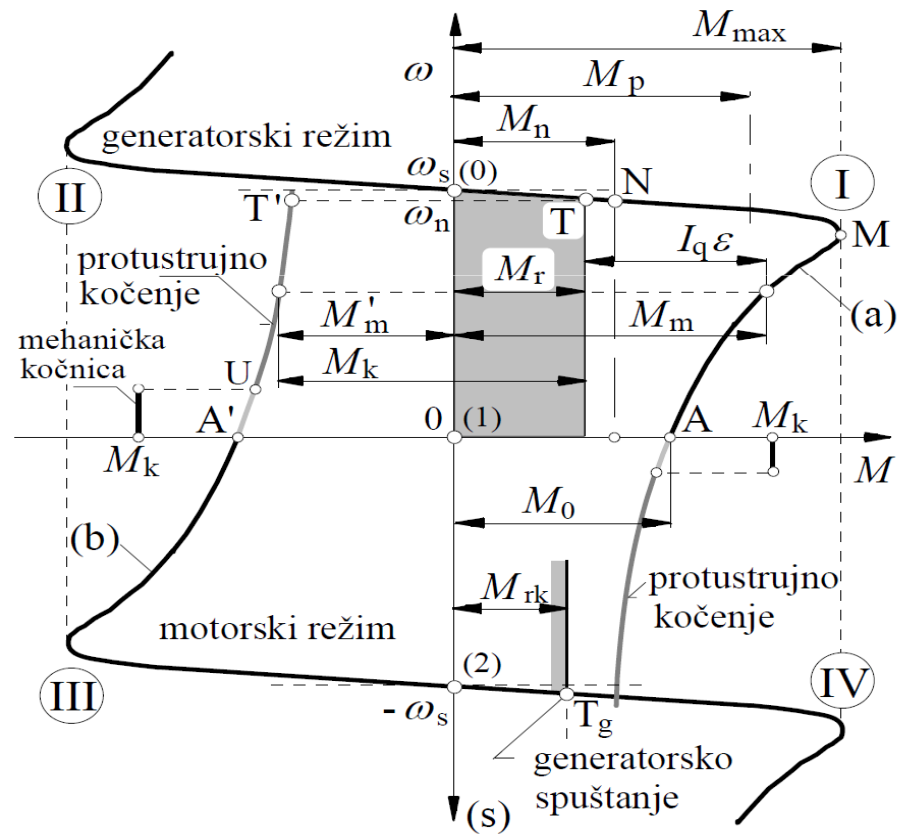

ZADATAK 8 (5)

$$M_p = 1,8M_n \geq M_{st} + M_{ub}$$

Nominalni moment EM – na vratilu EM

$$M_n = \frac{P_{EM}}{\omega_{EM}} = \frac{P_{EM}}{2\pi \cdot n_{EM}} = \frac{1500}{2\pi \cdot n_{EM}} = \frac{1500}{2\pi \cdot \frac{975}{60}} = 14,69 \text{ Nm}$$

Moment ustaljene vožnje reduciran na vratilo EM-a

$$M_{st} = (Q_t + m_v) g \cdot f_e \cdot \frac{D_k}{2} \cdot \frac{1}{\eta_{red}} \cdot \frac{1}{i_{red}}$$

$$M_{st} = (25 + 5) \cdot 9,81 \cdot 10 \cdot \frac{0,35}{2} \cdot \frac{1}{0,9} \cdot \frac{1}{55} = 10,4 \text{ Nm}$$



ZADATAK 8 (6)

Moment ubrzanja masa – mase potrebno reducirati na vratilo EM

$$M_{\text{ub}} = (J_{\text{rot}} + J_{\text{tr}}) \varepsilon$$

$$J_{\text{rot}} = J_{\text{EM}} + J_{\text{S}} = 0,0325 + 0,06 = 0,0925 \quad \text{kgm}^2$$

$$W = (m_v + Q_t) \cdot \frac{v_v^2}{2} = J_{\text{tr}} \cdot \frac{\omega_{\text{EM}}^2}{2} \cdot \eta_{\text{red}}$$

$$J_{\text{tr}} = \frac{m_v + Q_t}{\eta_{\text{uk}}} \cdot \left(\frac{v}{\omega_{\text{EM}}} \right)^2 = \frac{m_v + Q_t}{\eta_{\text{uk}}} \cdot \left(\frac{v}{2\pi \cdot n_{\text{EM}}} \right)^2$$

$$J_{\text{tr}} = \frac{5 + 25}{0,9} \cdot 1000 \cdot \left(\frac{20}{2\pi \cdot 975} \right)^2 = 0,35528 \quad \text{kgm}^2$$



ZADATAK 8 (7)

Kutno ubrzanje – UBRZANJE VRATILA EM-a !!!

$$\varepsilon = \frac{\omega_{EM}}{t} = \frac{2\pi \cdot n_{EM}}{t} = \frac{2\pi \cdot 975}{60 \cdot 3} = 34 \text{ s}^{-1}$$

Uvrštavanje....

$$M_{ub} = (J_{rot} + J_{tr}) \varepsilon = (0,0925 + 0,35528) \cdot 34 = 15,21 \text{ Nm}$$

$$M_p = 1,8M_n \geq M_{st} + M_{ub}$$

$$1,8 \cdot 14,69 \geq 10,4 + 15,21$$

$$26,44 \geq 25,61$$

ZADOVOLJAVA



ZADATAK 8 (8)

d) Izračunati graničnu brzinu mosta

$$s = \int_0^t v dt = \frac{1}{2} \cdot v_{gr} (t_{p,gr} + t_{k,gr})$$

$$t_{p,gr} = \frac{v_{gr}}{a_{p,t}} \quad t_{k,gr} = \frac{v_{gr}}{a_{k,t}}$$

$$a_{p,gr} = a_p \quad a_{k,gr} = a_k$$

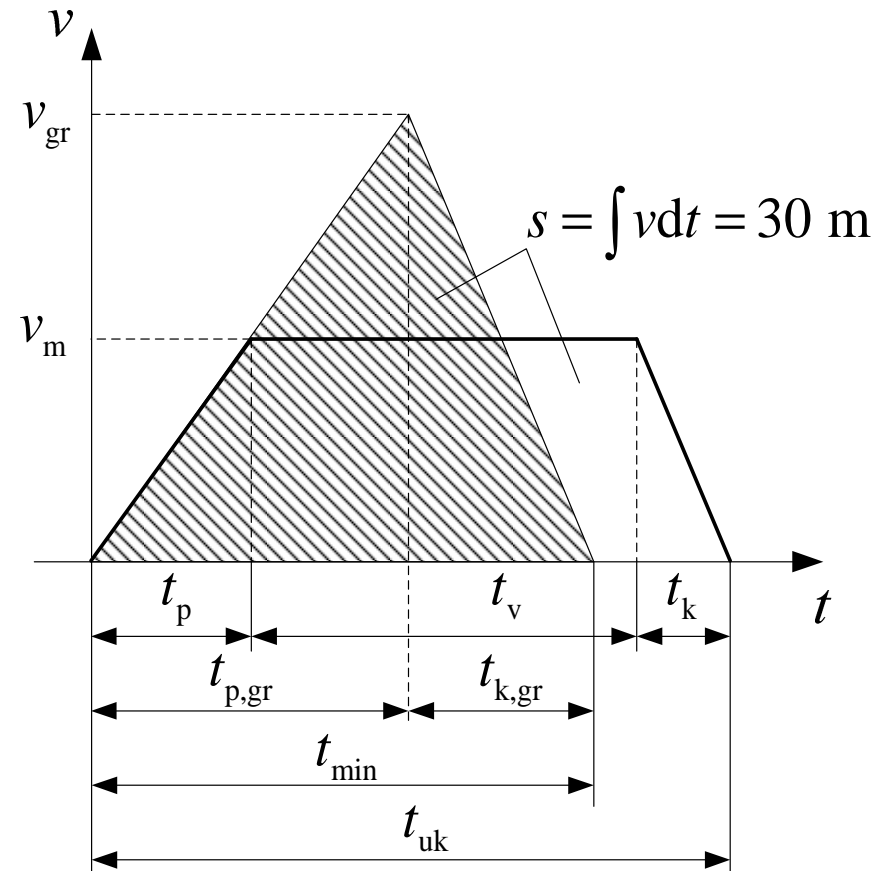

ZADATAK 8 (9)

$$a_p = \frac{v_v}{t_p} = \frac{20}{60 \cdot 3} = 0,111 \qquad a_k = a_p = 0,111$$

$$v_{gr} = \sqrt{\frac{2 \cdot s \cdot a_{p,t} \cdot a_{k,t}}{a_{p,t} + a_{k,t}}} = \sqrt{\frac{2 \cdot 10 \cdot 0,111 \cdot 0,111}{0,111 + 0,111}}$$

$$v_{gr} = 1,02 \qquad v_{gr} = 61,58$$

$$k = \frac{v_v}{v_{gr}} = \frac{20}{61,58} = 0,32 \approx \frac{1}{3}$$



ZADATAK 9 (1)

Za različite načine oslanjanja vitla prema slici, potrebno izračunati i usporediti opterećenje kotača i veličinu otpora vožnje, ako je zadano:

$$Q + G = 100 \text{ kN}; \quad a = 0,6 \text{ m}; \quad a_1 = 0,9 \text{ m}; \quad a_2 = 1,1 \text{ m};$$

$$b = 0,75 \text{ m}; \quad h = 1 \text{ m}; \quad f = 0,01$$

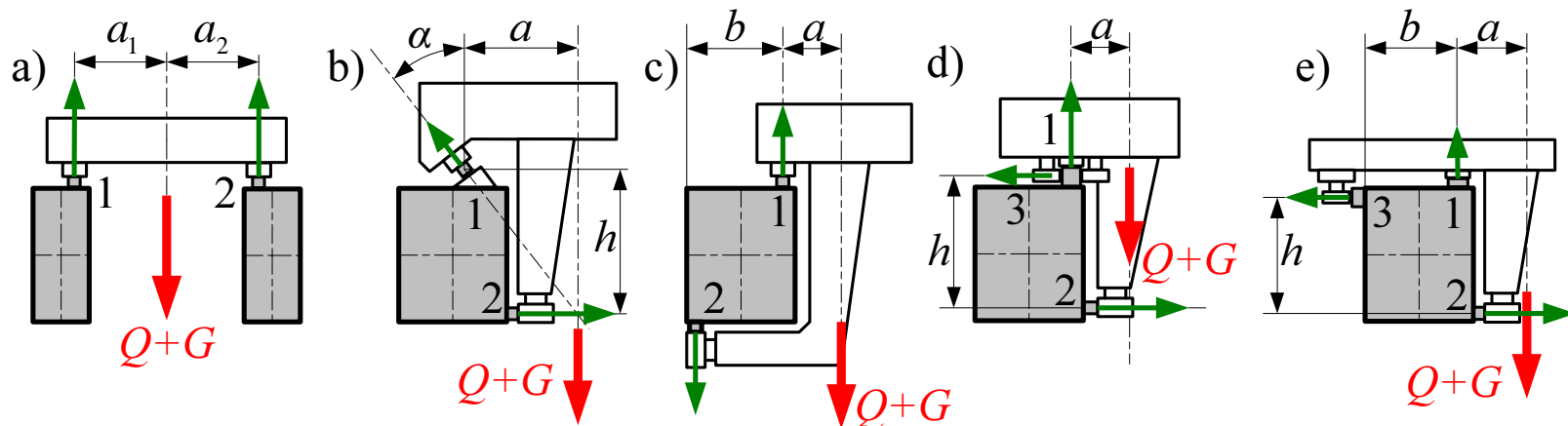

ZADATAK 9 (2)

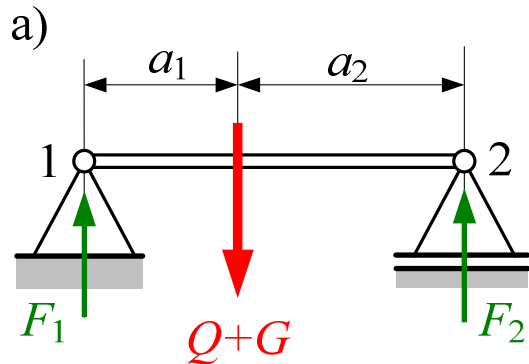

$$\sum F_y = 0 \Rightarrow F_1 + F_2 = Q + G$$

$$\sum M_2 = 0 \Rightarrow F_1(a_1 + a_2) = (Q + G) \cdot a_2$$

$$F_1 = \frac{a_2}{a_1 + a_2} \cdot (Q + G)$$

$$F_1 = \frac{1,1}{0,9 + 1,1} \cdot 100 = 55$$

$$F_2 = Q + G - F_1 = 100 - 55 = 45$$

$$F_f = (F_1 + F_2) \cdot f = (55 + 45)0,01 = 1$$



ZADATAK 9 (3)

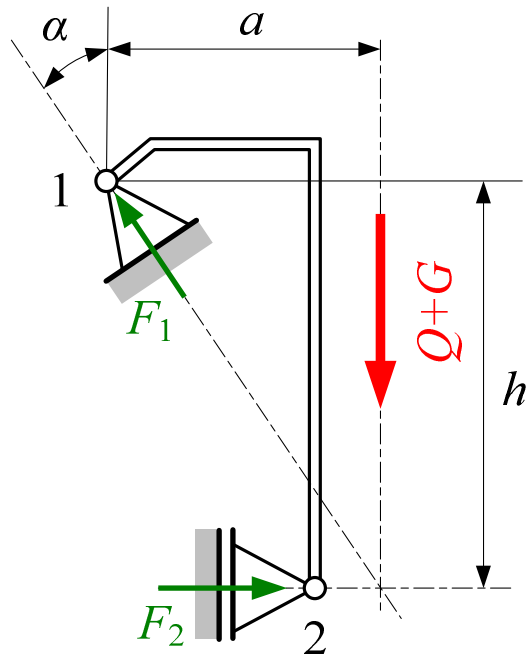

$$\sum M_1 = 0 \Rightarrow F_2 \cdot h = (Q + G) \cdot a$$

$$F_2 = (Q + G) \cdot \frac{a}{h} = 100 \cdot \frac{0,6}{1} = 60$$

$$\tan \alpha = \frac{a}{h} = \frac{0,6}{1} \Rightarrow \alpha = 30,96^\circ$$

$$\sum F_y = 0 \Rightarrow F_1 \cdot \cos \alpha = Q + G$$

$$F_1 = \frac{Q + G}{\cos \alpha} = \frac{100}{\cos 30,96^\circ} = 116,6$$

$$F_f = (F_1 + F_2) \cdot f$$

$$F_f = (116,6 + 60) \cdot 0,01 = 1,766$$

ZADATAK 9 (4)

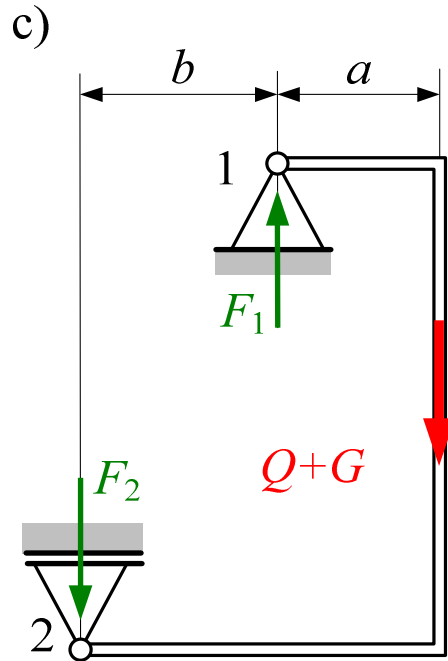

$$\sum M_1 = 0 \Rightarrow F_2 \cdot b = (Q + G) \cdot a$$

$$\sum F_y = 0 \Rightarrow F_2 = (Q + G) \cdot \frac{a}{b} = 100 \cdot \frac{0,6}{0,75} = 80$$

$$F_1 = F_2 + Q + G = 80 + 100 = 180$$

$$F_f = (F_1 + F_2) \cdot f$$

$$F_f = (180 + 80) \cdot 0,01 = 2,6$$



ZADATAK 9 (5)

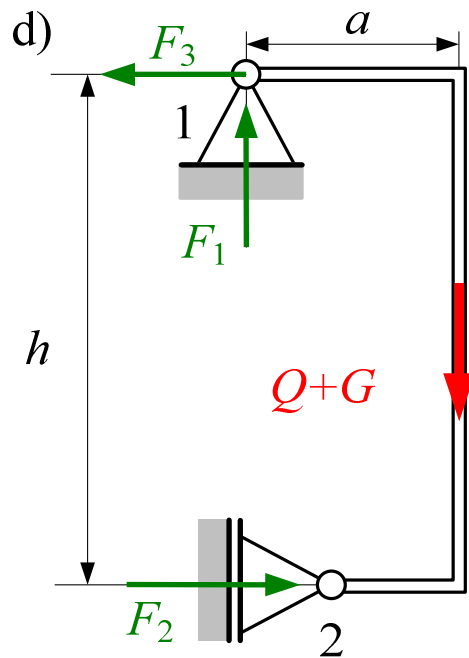

$$\sum M_1 = 0 \Rightarrow F_2 \cdot h = (Q + G) \cdot a$$

$$\sum F_y = 0 \Rightarrow F_1 = Q + G = 100$$

$$\sum F_x = 0 \Rightarrow F_2 = (Q + G) \cdot \frac{a}{h} = 100 \cdot \frac{0,6}{1} = 60$$

$$F_3 = F_2 = 60$$

$$F_f = (F_1 + F_2 + F_3) \cdot f$$

$$F_f = (100 + 60 + 60) \cdot 0,01 = 2,2$$



ZADATAK 9 (5)

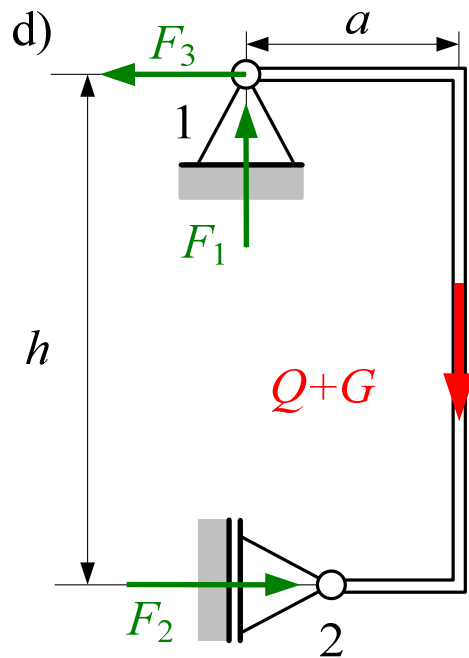

$$\sum M_1 = 0 \Rightarrow F_2 \cdot h = (Q + G) \cdot a$$

$$\sum F_y = 0 \Rightarrow F_1 = Q + G = 100$$

$$\sum F_x = 0 \Rightarrow F_2 = (Q + G) \cdot \frac{a}{h} = 100 \cdot \frac{0,6}{1} = 60$$

$$F_3 = F_2 = 60$$

$$F_f = (F_1 + F_2 + F_3) \cdot f$$

$$F_f = (100 + 60 + 60) \cdot 0,01 = 2,2$$

ZADATAK 9 (6)

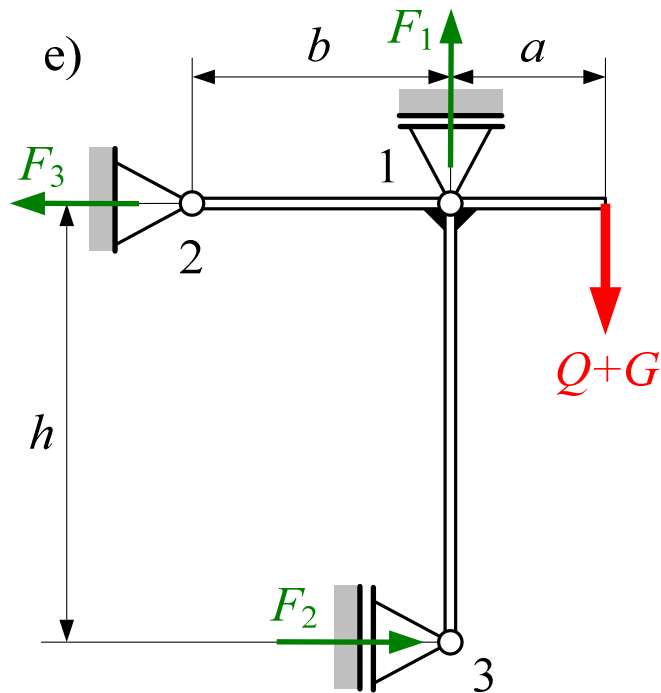

$$\sum M_1 = 0 \Rightarrow F_2 \cdot h = (Q + G) \cdot a$$

$$F_2 = (Q + G) \cdot \frac{a}{h} = 100 \cdot \frac{0,6}{1} = 60$$

$$\sum F_y = 0 \Rightarrow F_1 = Q + G = 100$$

$$\sum F_x = 0 \Rightarrow F_3 = F_2 = 60$$

$$F_f = (F_1 + F_2 + F_3) \cdot f$$

$$F_f = (100 + 60 + 60) \cdot 0,01 = 2,2$$

ZADATAK 10 (1)

Za kosi lift prema slici zadano je:

$m_{\text{kab}} = 1600$ kg, masa kabine;

$m = 800$ kg, nosivost lifta;

$v = 1,5$ m/s, brzina vožnje;

$a_1 = 0,5$ m/s² ubrzanje pri pokretanju i kočenju;

$\alpha = \frac{7}{6} \pi$ obuhvatni kut

α_{us} uspon staze 45%

$f = 0,02$ specifični otpori vožnje.

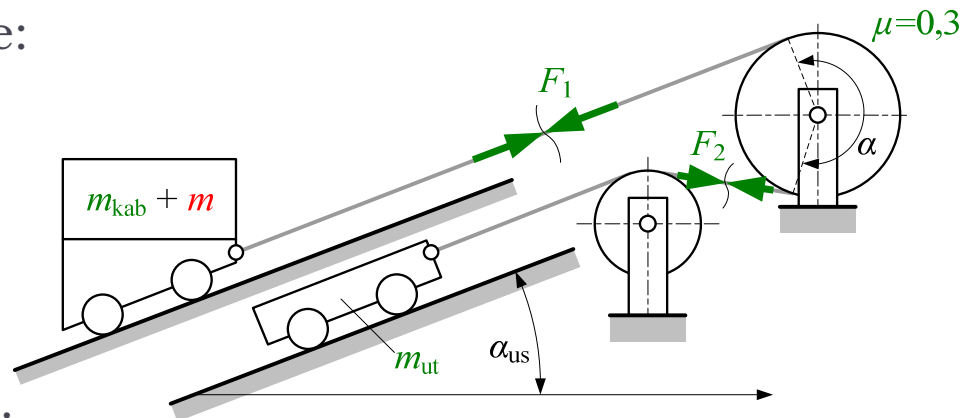

Odrediti (težinu užeta zanemariti):

- optimalnu masu utega iz uvjeta što manje pogonske sile;
- snagu pogona (ukupna iskoristivost $\eta = 0,7$) za izračunatu masu protuuutega;