

TRANSPORTNI UREĐAJI

VJEŽBE - 05

asistent: Matija Hoić, mag. ing. mech.

INFORMACIJE

- rok za predaju programa za studente koji su TU upisali drugi puta je kraj travnja 2011.
- ako do tada programski zadatak nije predan, mora se podići novi
- ukoliko se ne stigne izraditi trenutno zadani zadatak do tog datuma, javiti se da se zada novi
- neovisno o programskom zadatku, kolokviji položeni prošle akademske godine vrijede do kraja ovog semestra, tj. zaključno s posljednjim ispitnim rokom u ovom semestru koji će biti 07.07.2011.



ZADATAK 10 (1)

Za kosi lift prema slici zadano je:

Odrediti (težinu užeta zanemariti):

- optimalnu masu utega iz uvjeta što manje pogonske sile;
- snagu pogona (ukupna iskoristivost $\eta = 0,7$) za izračunatu masu protuutega;

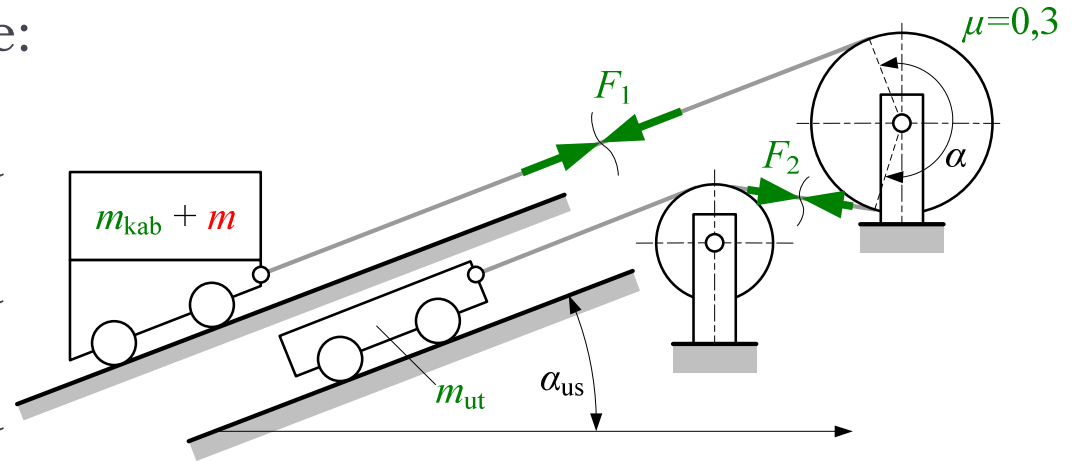

$$m_{ut} = m_{kab} + \frac{m}{2} \left(1 + \frac{f}{\tan \alpha_{us}} \right) = 1600 + \frac{800}{2} \left(1 + \frac{0,02}{0,45} \right) = 2018$$

$$P = \frac{F_p \cdot v}{\eta}$$

$$F_p = F_{p,a} = (m_{kab} + m - m_{ut}) \cdot g \cdot \sin \alpha_{us} + (m_{kab} + m + m_{ut}) \cdot g \cdot \cos \alpha_{us} \cdot f$$

ZADATAK 11 (1)

Za mehanizam dizanja auto-granikaprema slici potrebno je odrediti:

- Odnos pri dizanju i spuštanju tereta (F_{bub}/Q); $\eta_0 = 0,98$
- reduciranu masu tereta na obodu bubnja;
odnos pogonske sile u cilindru i tereta (F_{cil}/Q) pri dizanju kraka, težinu kraka zanemariti;
- reduciranu masu tereta na linijsku ogonsku koordinatu $r = q$

Za referentnu koordinatu pi analizi uzeti kuteve φ_2 i φ_1



ZADATAK 11 (2)

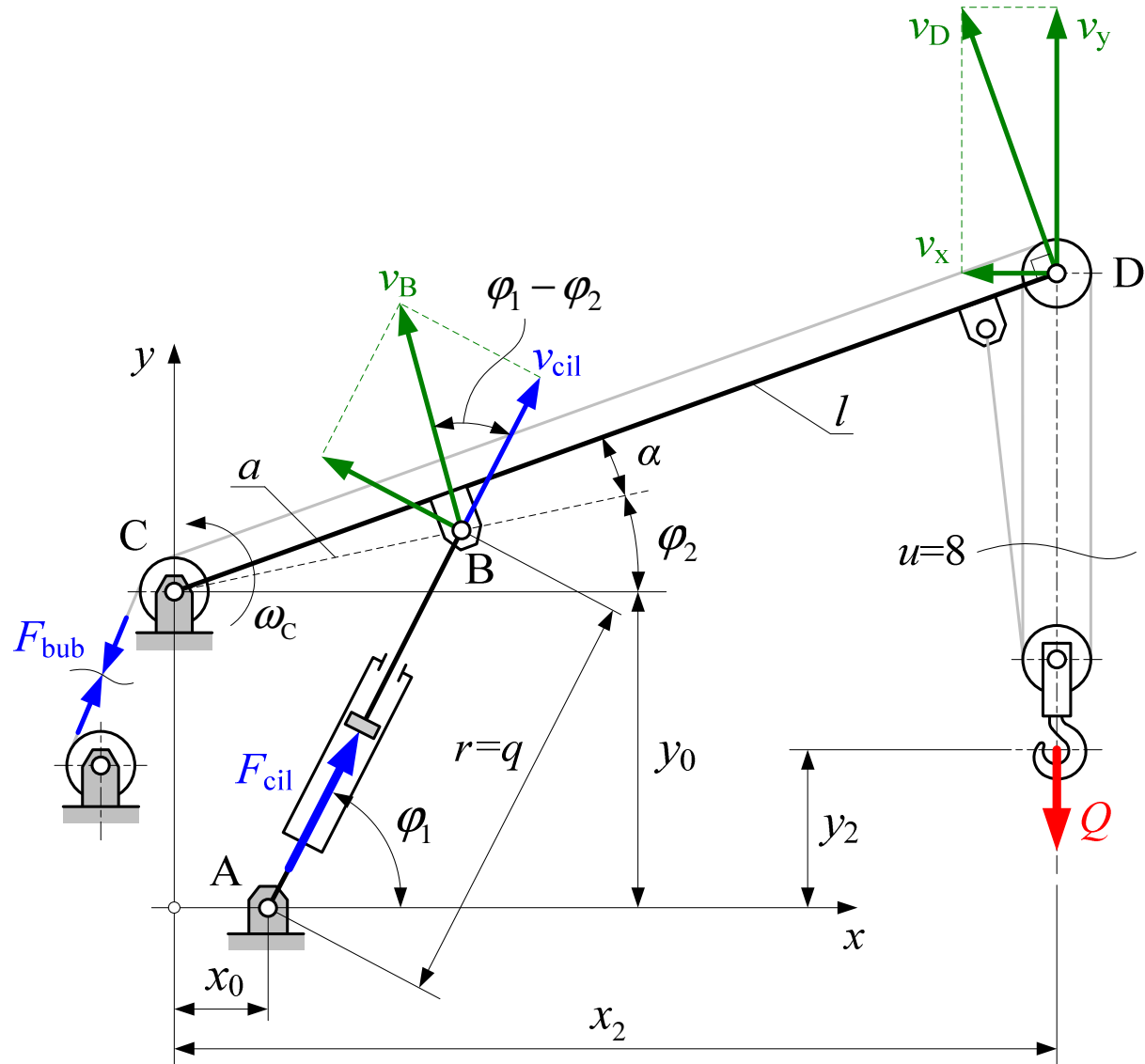

ZADATAK 11 (3)

- ODNOS F_{bub}/Q PRI DIZANJU I SPUŠTANJU TERETA

$$F_{\text{bub}} \cdot \eta_r = \frac{Q}{i_{\text{fk}}} \quad i_{\text{fk}} = u = 8$$

$$\eta_{0,r} = \eta_0 = 0,98 \quad \eta_{\text{fk},r} = \frac{1}{u} \cdot \frac{1 - \eta_0^u}{1 - \eta_0} = \frac{1}{8} \cdot \frac{1 - 0,98^8}{1 - 0,98} = 0,9327$$

$$\eta_r = \eta_{\text{fk},r} \cdot \eta_{0,r}^2 = 0,9327 \cdot 0,98^2 = 0,8957$$

$$\left(\frac{F_{\text{bub}}}{Q} \right)_r = \frac{1}{\eta_r \cdot i_{\text{fk}}} = \frac{1}{0,8957 \cdot 8} = 0,1395$$



ZADATAK 11 (4)

- ODNOS F_{bub}/Q PRI DIZANJU I SPUŠTANJU TERETA

$$F_{\text{bub}} = \frac{Q}{i_{\text{fk}}} \cdot \eta_{\text{k}} \quad i_{\text{fk}} = u = 8$$

$$\eta_{0,\text{k}} = 2 - \frac{1}{\eta_{0,\text{r}}} = 2 - \frac{1}{0,98} = 0,9796 \quad \eta_{\text{fk},\text{k}} = 2 - \frac{1}{\eta_{\text{fk},\text{r}}} = 2 - \frac{1}{0,9327} = 0,9278$$

$$\eta_{\text{k}} = \eta_{\text{fk},\text{k}} \cdot \eta_{0,\text{k}}^2 = 0,9278 \cdot 0,9796^2 = 0,8904$$

$$\left(\frac{F_{\text{bub}}}{Q} \right)_{\text{k}} = \frac{\eta_{\text{k}}}{i_{\text{fk}}} = \frac{0,8903}{8} = 0,1111$$



ZADATAK 11 (5)

- REDUCIRANA MASA TERETA NA OBODU BUBNJA

Reducirana masa tereta na obodu bubnja zbog male mase rotirajućih članova (užnica) naspram tereta jednaka je reduciranim translacijskim masama:

$$W = I_R \cdot \frac{\omega_{\text{bub}}^2}{2} = \frac{Q}{g} \cdot \frac{v_D^2}{2} \cdot \frac{1}{\eta_r} \quad \Rightarrow \quad I_R = I_{\text{tr}} = \frac{Q}{g} \cdot \left(\frac{v_D}{\omega_{\text{bub}}} \right)^2 \cdot \frac{1}{\eta_r}$$

$$\frac{v_D}{\omega_{\text{bub}}} = \frac{v_D}{v_{\text{bub}}/r_{\text{bub}}} = \frac{r_{\text{bub}}}{u}$$

$$I_R = I_{\text{tr}} = \frac{Q}{g} \cdot \left(\frac{r_{\text{bub}}}{u} \right)^2 \cdot \frac{1}{\eta_r} = \frac{Q}{9,81} \cdot \frac{r_{\text{bub}}^2}{8^2} \cdot \frac{1}{0,8957} = 0,00178 \cdot Q \cdot r_{\text{bub}}^2$$



ZADATAK 11 (6)

•ODNOS POGONSKE SILE U CILINDRU I TERETA (REDUKCIJA TERETA NA POGONSKU SILU U CILINDRU)

$$P_{\text{cil}} = P_t \quad \Rightarrow \quad F_{\text{cil}} \cdot v_{\text{cil}} = Q \cdot v_y$$

$$\left. \begin{array}{l} v_y = v_D \cdot \cos(\alpha + \varphi_2) \\ v_D = \omega_C \cdot l \end{array} \right\} v_y = \omega_C \cdot l \cdot \cos(\alpha + \varphi_2)$$

$$\left. \begin{array}{l} v_{\text{cil}} = v_B \cdot \sin(\varphi_1 - \varphi_2) \\ v_B = \omega_C \cdot a \end{array} \right\} v_r = \omega_C \cdot a \cdot \sin(\varphi_1 - \varphi_2)$$

$$\frac{F_c}{Q} = \frac{v_y}{v_r} = \frac{l}{a} \cdot \frac{\cos(\alpha + \varphi_2)}{\sin(\varphi_1 - \varphi_2)}$$



ZADATAK 11 (7)

•REDUCIRANA MASA TERETA NA LINIJSKU POGONSKU KOORDINATU

$$\frac{1}{2}m_{\text{red}} \cdot v_{\text{cil}}^2 = \frac{1}{2}m_{\text{Q}} \cdot v_{\text{D}}^2 \quad \Rightarrow \quad m_{\text{red}} = m_{\text{Q}} \cdot \left(\frac{v_{\text{D}}}{v_{\text{cil}}} \right)^2$$

Pri čemu se brzina točke D radi lakšeg pisanja jednadžbi rastavlja na horizontalnu i vertikalnu komponentu:

$$m_{\text{red}} = m_{\text{Q}} \cdot \left[\left(\frac{v_x}{v_{\text{cil}}} \right)^2 + \left(\frac{v_y}{v_{\text{cil}}} \right)^2 \right]$$



ZADATAK 11 (8)

$$\left. \begin{array}{l} v_x = v_D \cdot \sin(\alpha + \varphi_2) \\ v_D = \omega_C \cdot l \end{array} \right\} v_x = \omega_C \cdot l \cdot \sin(\alpha + \varphi_2)$$

$$m_{\text{red}} = m_Q \cdot \left(\frac{l}{a}\right)^2 \cdot \frac{\sin^2(\alpha + \varphi_2) + \cos^2(\alpha + \varphi_2)}{\sin^2(\varphi_1 - \varphi_2)}$$

$$m_{\text{red}} = \frac{Q}{g} \cdot \left(\frac{l}{a} \sin(\varphi_1 - \varphi_2)\right)^2$$



ZADATAK 12 (1)

Izvršiti redukciju tereta i mase tereta na pogonsku koordinatu r za zadani mehanizam prema slici. Za referentnu koordinatu uzeti kut φ_2

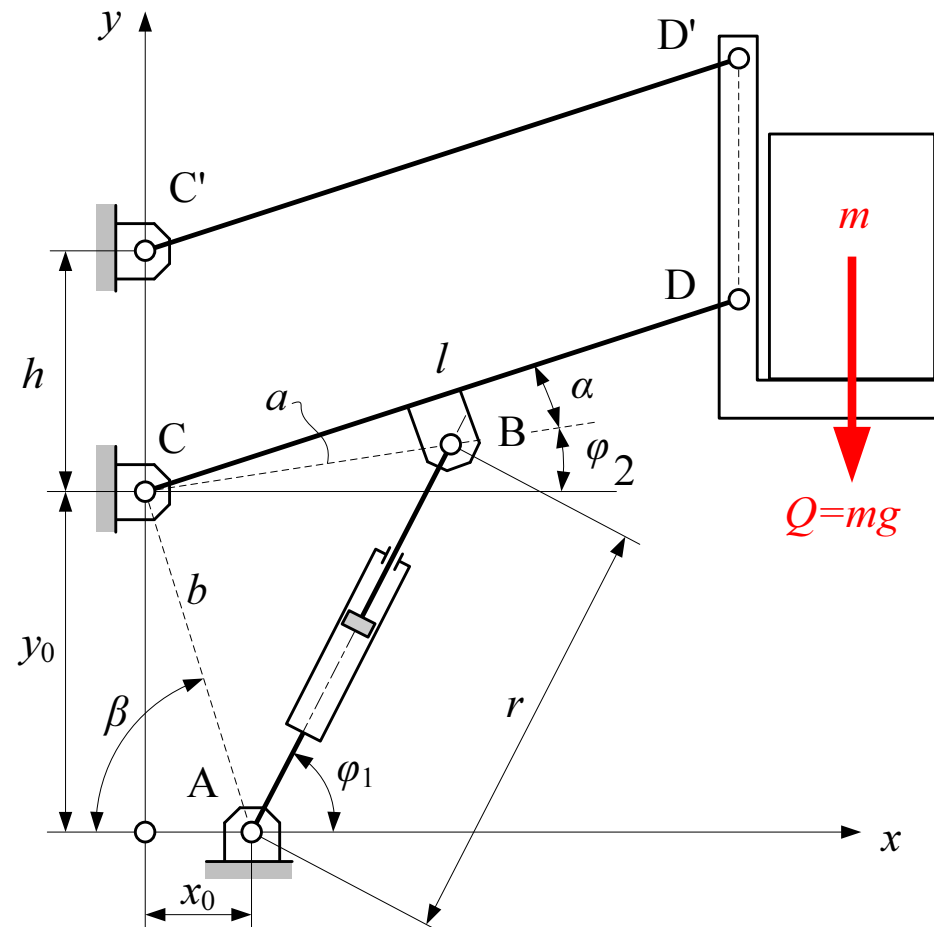

ZADATAK 12 (2)

REDUKCIJA TERETA (TEŽINA) – PREKO JEDNADŽBI RAVNOTEŽE

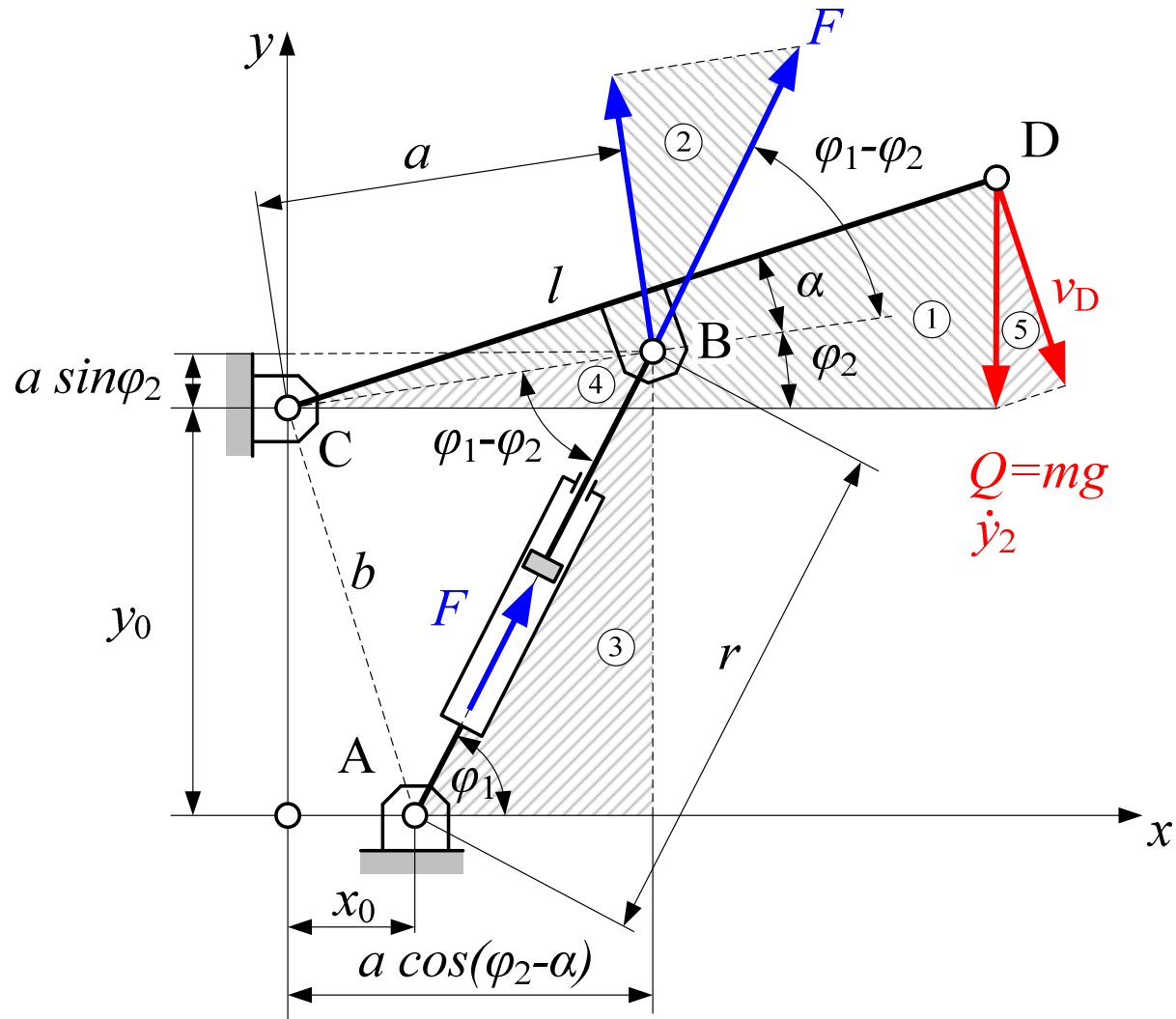

ZADATAK 12 (3)

REDUKCIJA TERETA (TEŽINA) – PREKO JEDNADŽBI RAVNOTEŽE

Trokuti (1), (2) i (5)

$$\sum M_C = 0 \quad \Rightarrow \quad a \cdot F \sin(\varphi_1 - \varphi_2) = Q \cdot l \cos(\varphi_2 + \alpha)$$

$$F = Q \cdot \frac{l \cos(\varphi_2 + \alpha)}{a \sin(\varphi_1 - \varphi_2)} = Q \cdot \frac{dy_2}{dr} = Q \cdot \frac{\dot{y}_2}{v_r}$$

Trokuti (3) i (4)

$$\operatorname{tg} \varphi_1 = \frac{y_0 + a \sin \varphi_2}{a \cos \varphi_2 - x_0}$$



ZADATAK 12 (4)

REDUKCIJA TERETA (TEŽINA) – PREKO SNAGE

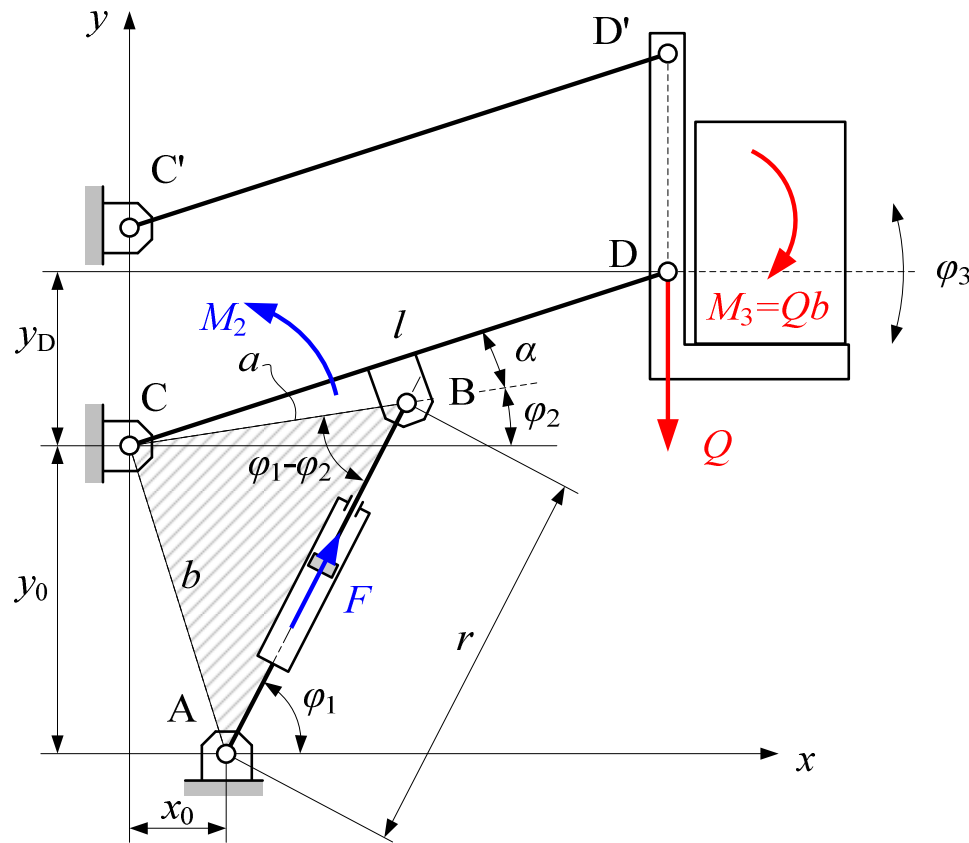

$$M_2 d\varphi_2 = Q dy_D + M_3 d\varphi_3$$

$$M_2 = Q \frac{dy_D}{d\varphi_2} + M_3 \frac{d\varphi_3}{d\varphi_2}$$

ZADATAK 12 (5)

REDUKCIJA TERETA (TEŽINA) – PREKO SNAGE

$$M_2 d\varphi_2 = F dr \quad \Rightarrow \quad M_2 = F \frac{dr}{d\varphi_2}$$

Iz kosinusovog poučka za naznačeni trokut slijedi

$$b^2 = r^2 + a^2 - 2ra \cos(\varphi_1 - \varphi_2) \quad \Rightarrow \quad 0 = 2rdr - 2ra \sin(\varphi_1 - \varphi_2) d\varphi_2$$

$$\frac{dr}{d\varphi_2} = a \sin(\varphi_1 - \varphi_2)$$

$$y_D = l \sin(\alpha + \varphi_2) \quad \Rightarrow \quad \frac{dy_D}{d\varphi_2} = l \cos(\alpha + \varphi_2) \quad \frac{d\varphi_3}{d\varphi_2} = 0$$



ZADATAK 12 (6)

REDUKCIJA TERETA (TEŽINA) – PREKO SNAGE

$$F \frac{dr}{d\varphi_2} = Q \frac{dy_D}{d\varphi_2} + M_3 \frac{d\varphi_3}{d\varphi_2}$$

$$F \cdot a \sin(\varphi_1 - \varphi_2) = Q \cdot l \cos(\alpha + \varphi_2) + M_3 \cdot 0$$

$$F = Q \cdot \frac{l \cos(\varphi_2 + \alpha)}{a \sin(\varphi_1 - \varphi_2)}$$



ZADATAK 12 (7)

REDUKCIJA MASE TERETA

$$\frac{1}{2}m_r \cdot v_r^2 = \frac{1}{2}m \cdot v_D^2$$

$$\frac{\dot{y}_2}{v_D} = \cos(\alpha + \varphi_2) \quad \Rightarrow \quad v_D = \frac{\dot{y}_2}{\cos(\alpha + \varphi_2)}$$

$$m_r = m \cdot \left(\frac{v_D}{v_r} \right)^2 = m \cdot \left(\frac{\dot{y}_2}{v_r} \cdot \frac{1}{\cos(\alpha + \varphi_2)} \right)^2$$

$$m_r = m \cdot \left(\frac{l \cos(\varphi_2 + \alpha)}{a \sin(\varphi_1 - \varphi_2)} \cdot \frac{1}{\cos(\alpha + \varphi_2)} \right)^2 = m \cdot \left(\frac{l}{a \sin(\varphi_1 - \varphi_2)} \right)^2$$



ZADATAK 13 (1)

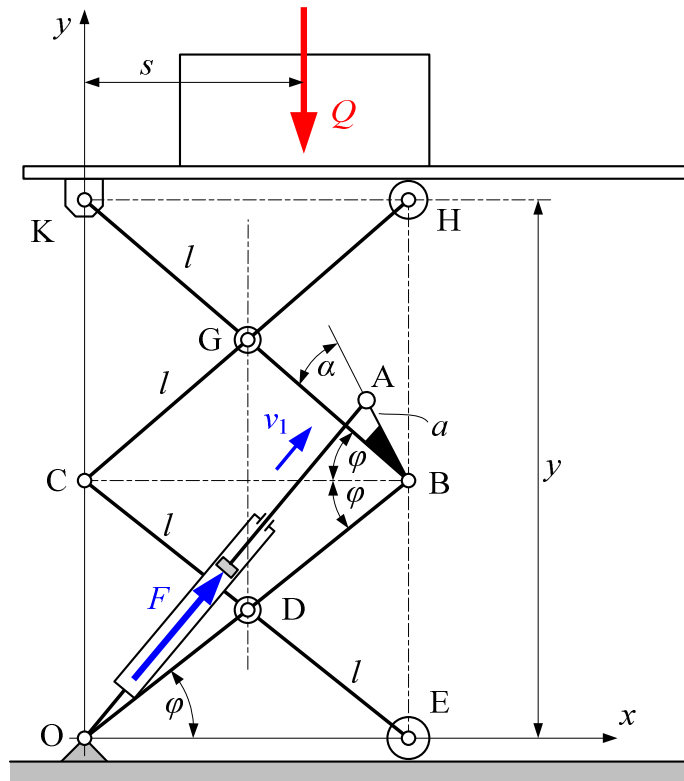

$$F/Q = f(\varphi) = ?$$

$$15^\circ \leq \varphi \leq 60^\circ$$

$$\alpha = 20^\circ$$

$$l/a = 2$$



ZADATAK 13 (2)

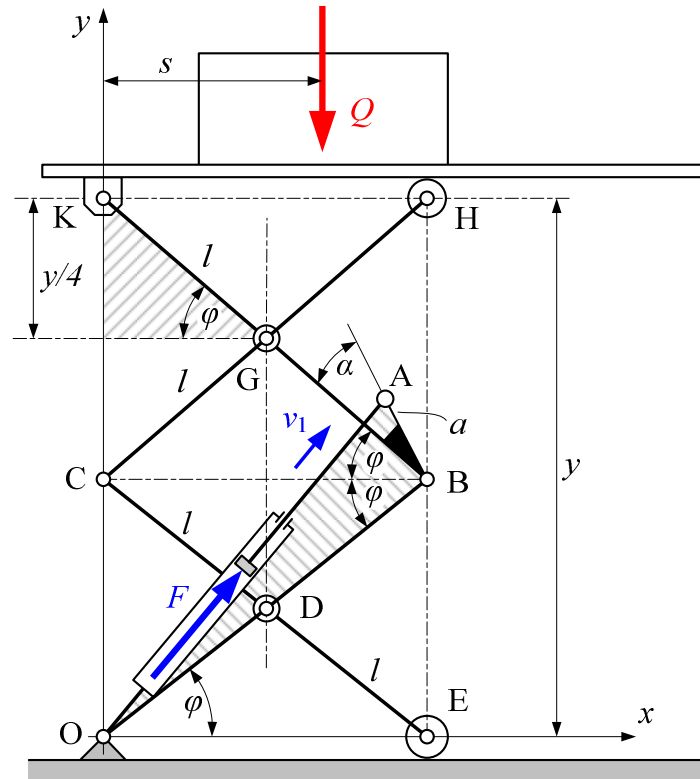

$$\frac{F}{Q} = \frac{dy}{dr} = \frac{v_y}{v_1}$$

$$y = 4l \sin \varphi \quad \Rightarrow \quad dy = 4l \cos \varphi d\varphi$$

$$r^2 = (2l)^2 + a^2 - 4a \cdot l \cos(2\varphi + \alpha)$$

$$2r dr = -4al (-\sin(2\varphi + \alpha)) \cdot 2$$

$$dr = \frac{4a \cdot l}{r} \cdot \sin(2\varphi + \alpha) d\varphi$$



ZADATAK 13 (3)

$$\frac{F}{Q} = \frac{dy}{dr} = \frac{\cos \varphi}{\sin(2\varphi + \alpha)} \sqrt{1 + 4\left(\frac{l}{a}\right)^2 - 4\frac{l}{a} \cos(2\varphi + \alpha)}$$

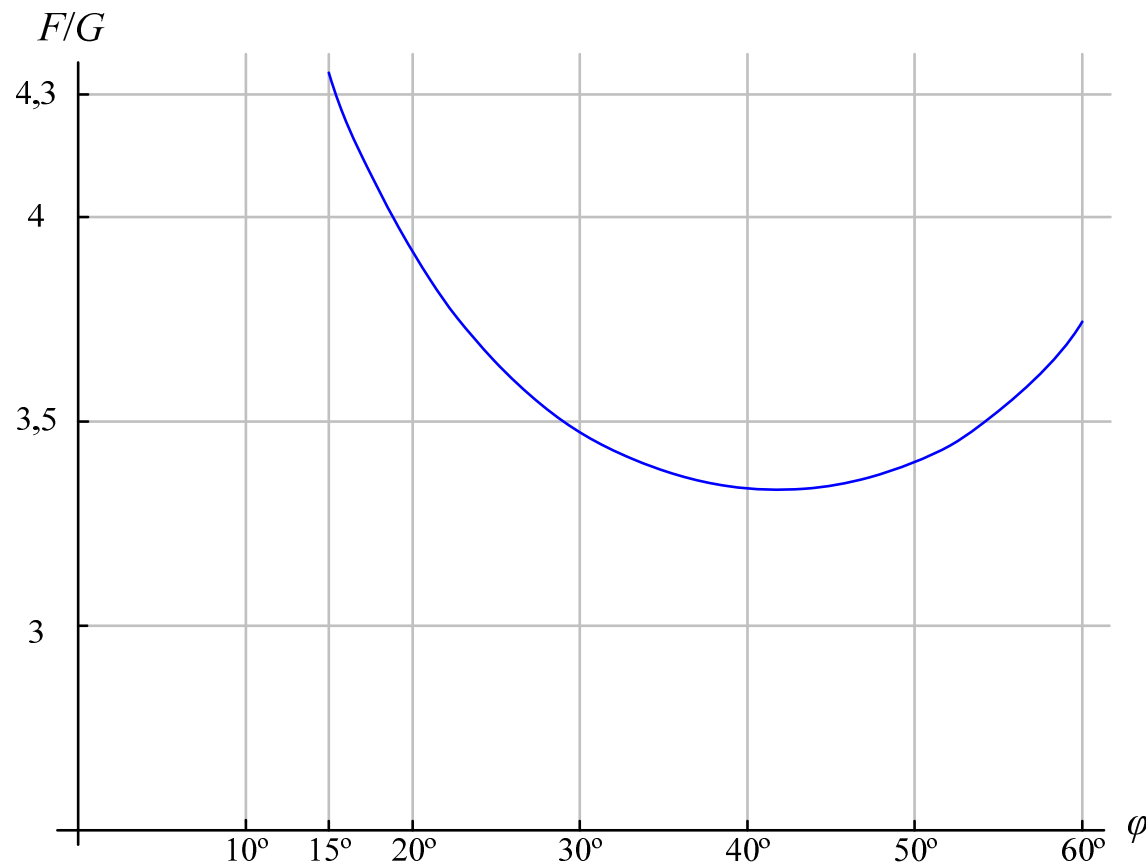

HIDRAULIČNI POGON

F je uvijek veći od Q –

MULTIPLIKACIJA SILE !!!



ZADATAK 14 (1)

Za vježbu....

Za podizni mehanizam prema slici odrediti:

- sile u pogonskim cilindrima kao funkciju položaja radne košare;

- sile u štapovima $\overline{A_1B_1}$

i $\overline{B_2C_1}$

Za referentne koordinate uzeti :

φ_2 i φ_1

Težine mehanizma zanemariti. polužja

