

Relativni troškovi za sučeone i kutne zavare

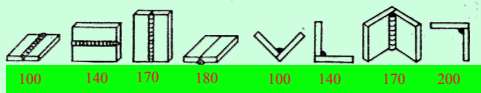

Zavari



statički

dinamički

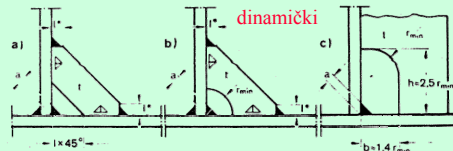

Zavari



Izbjegavati zavare u zoni strojne obrade!

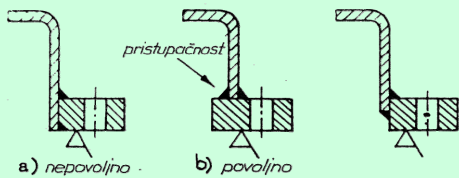

Zavari



Korijen zavora u zonu strojne obrade!

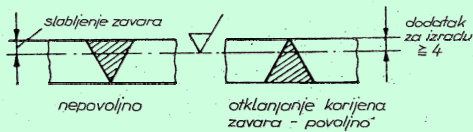

Zavari

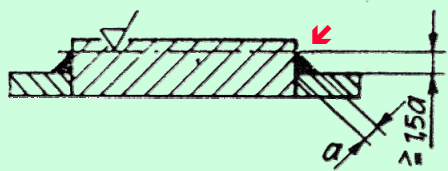

Zavari

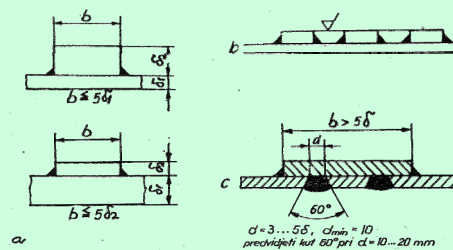

Ojačanja kroz provrte

Zavari



Povećanje širine

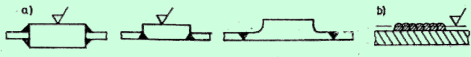

Zavari



Sprečavanje ispučenja kod žarenja

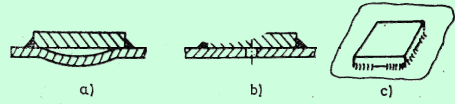

Zavari

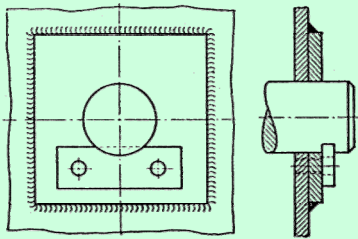

Povećanje površine nalijeganja

Zavari

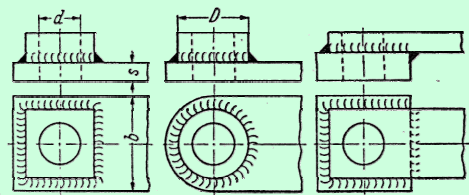

Povećanje površine nalijeganja

Zavari



Prodiranje strogotine

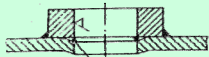

a)

loše

Prodiranje ulja



b)



c)

dobro

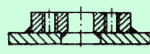

d)

Zavari



Prirubnički spojevi

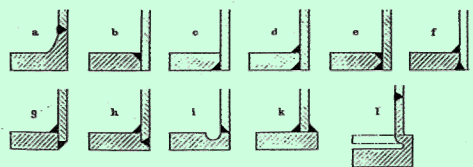

Zavari



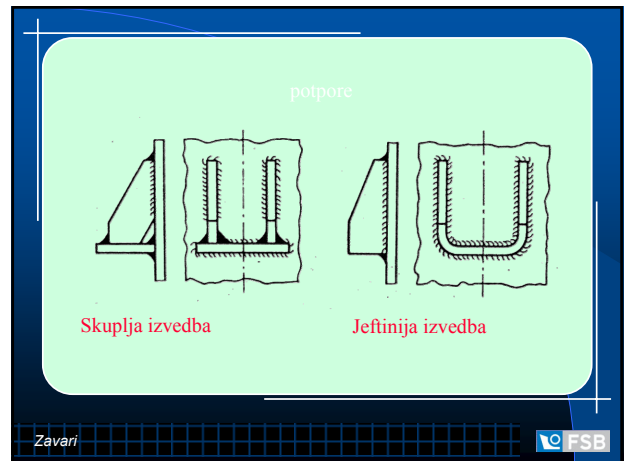
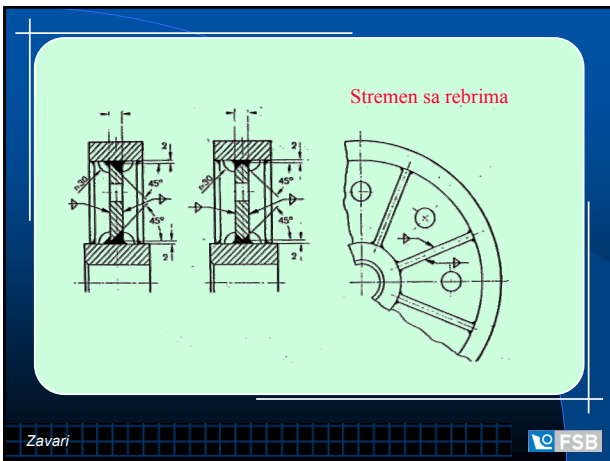
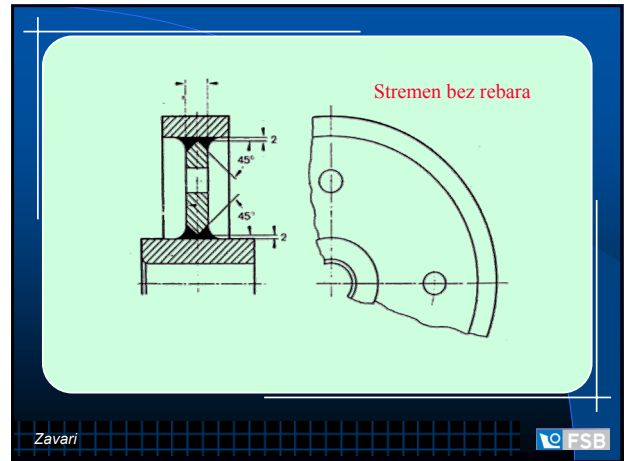
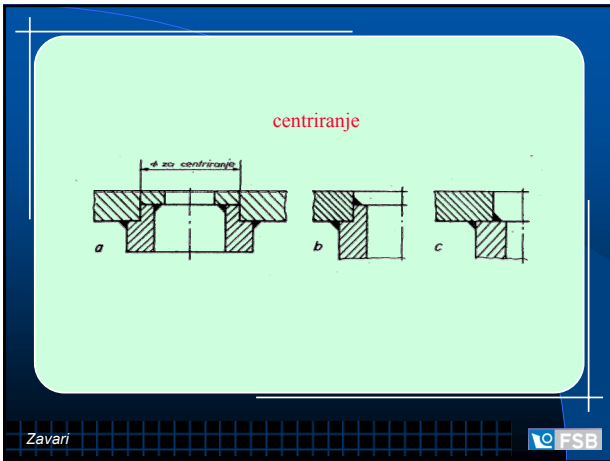
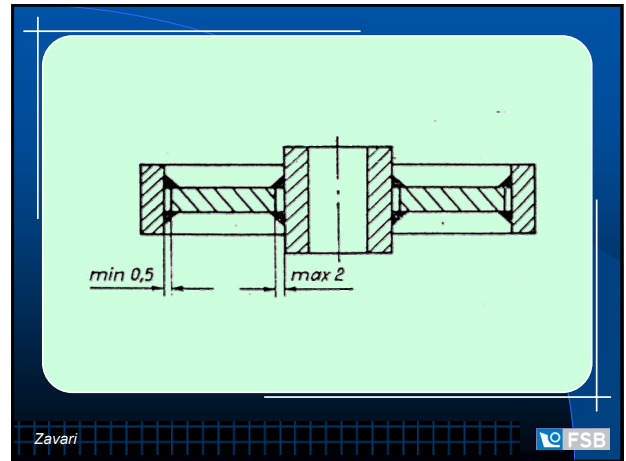
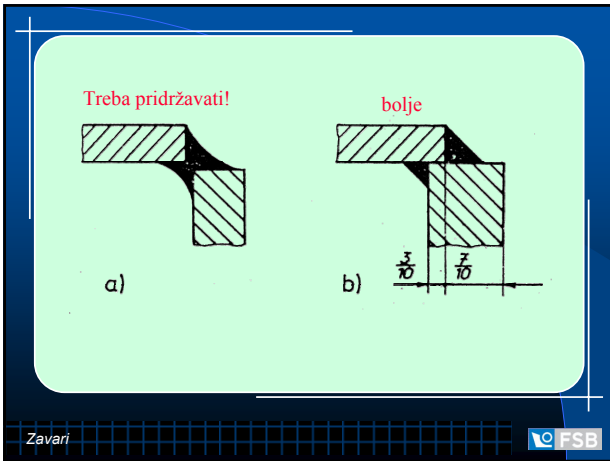

Spojevi sa temeljnim vijcima

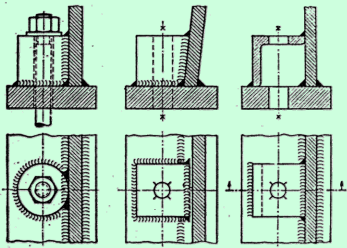

Zavari

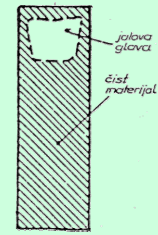

Zavari

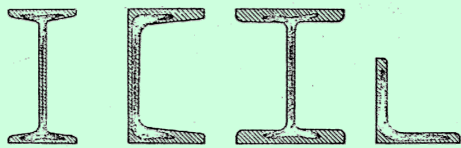

Zavari

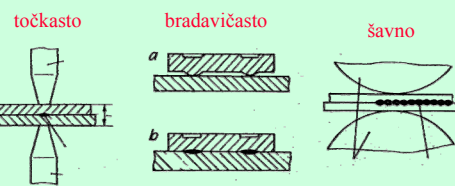

Zavari



Opasnost korozije

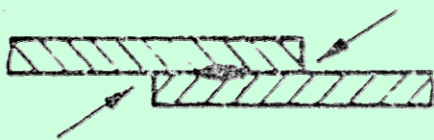

Zavari

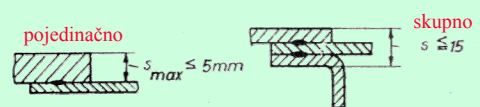

Zavari



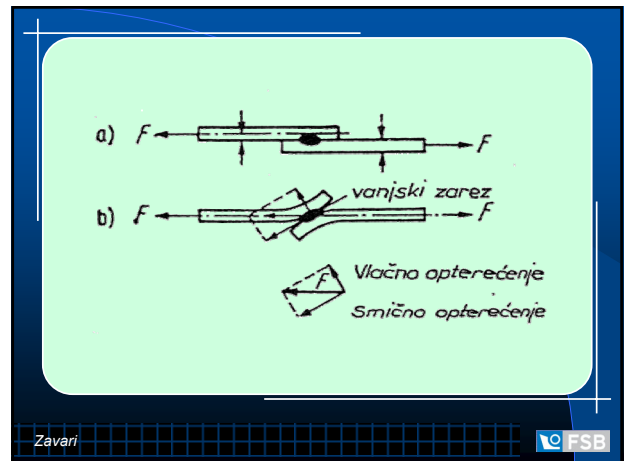
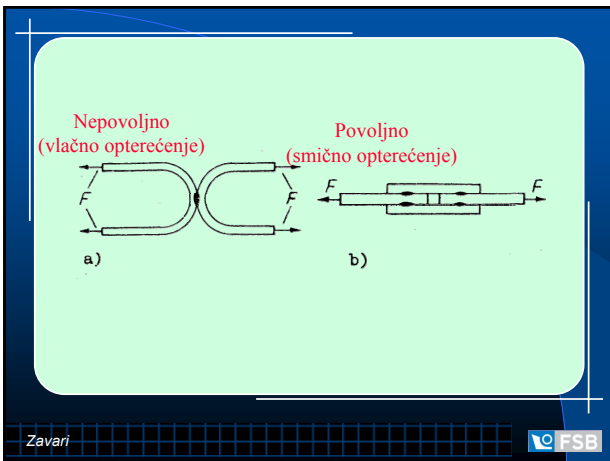
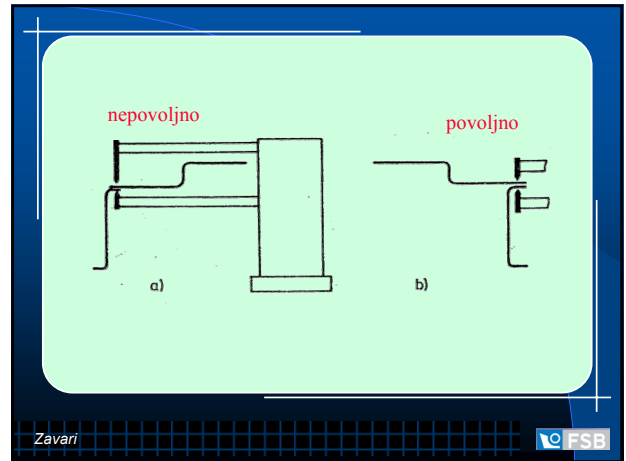
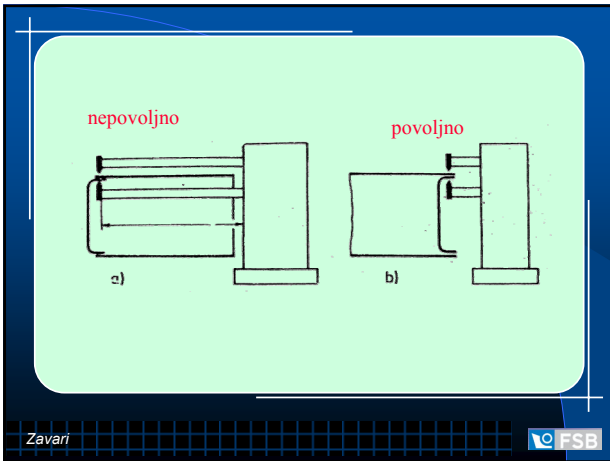
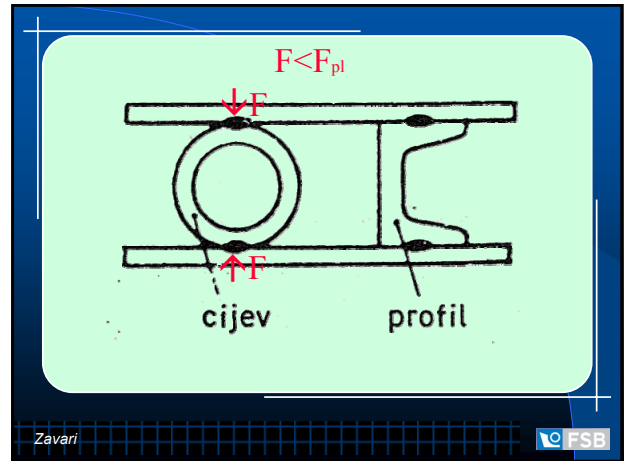
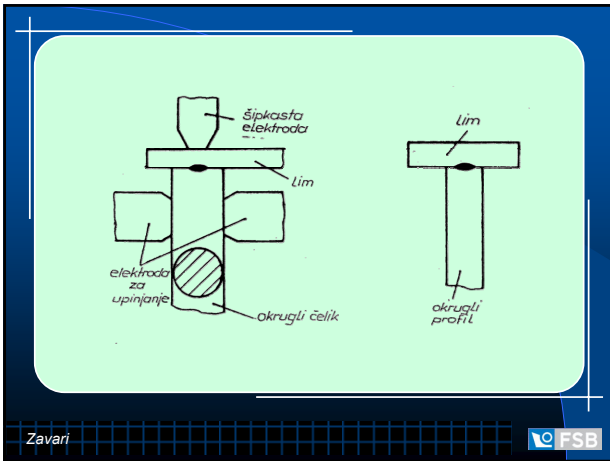

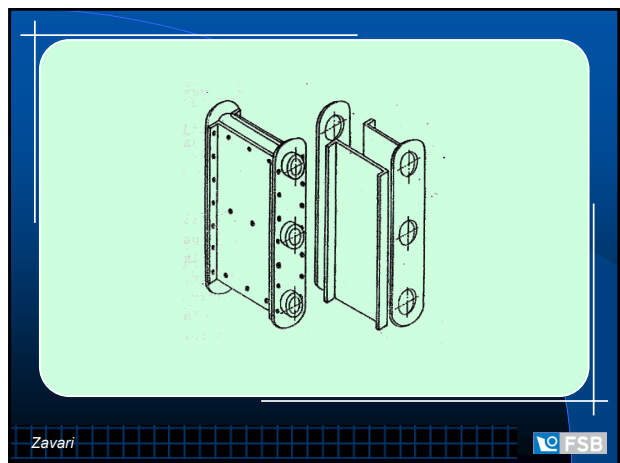
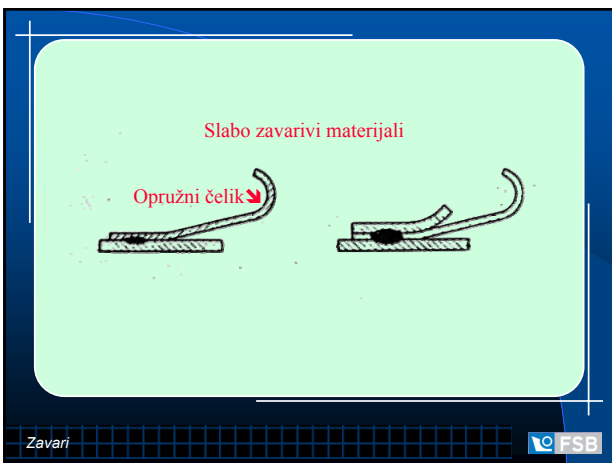
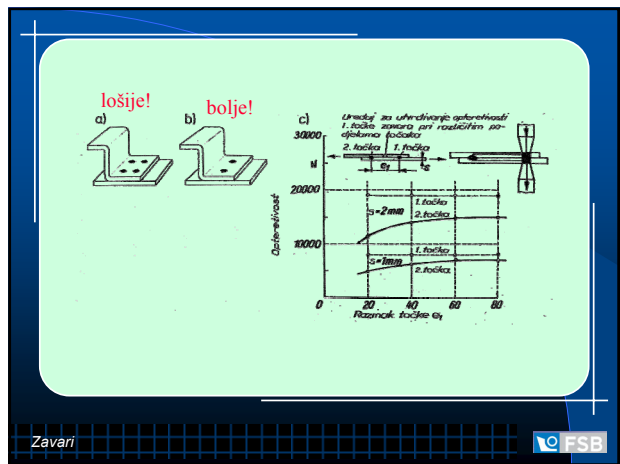
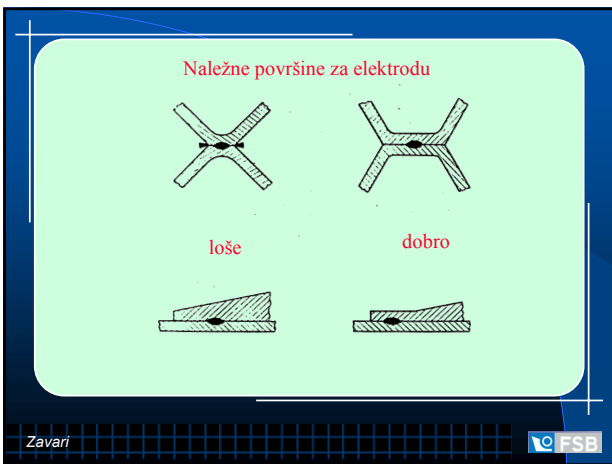
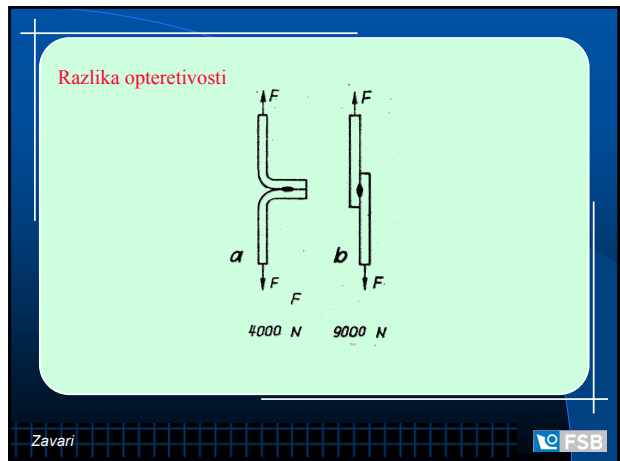
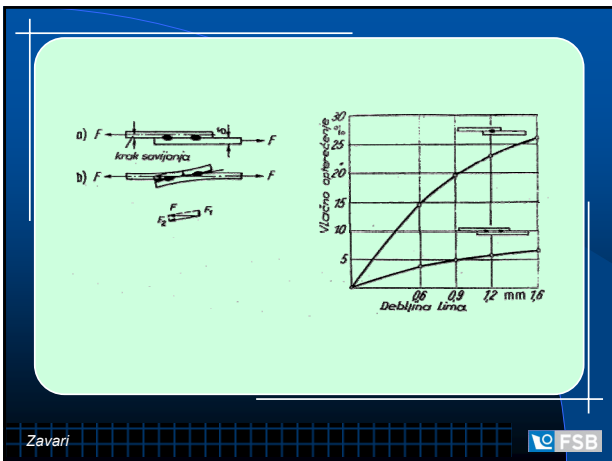

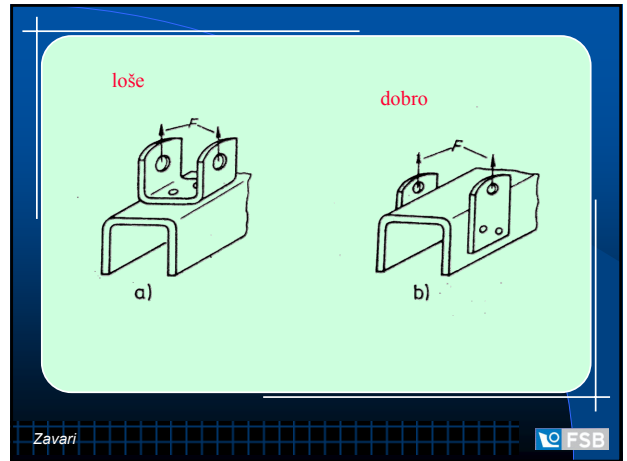
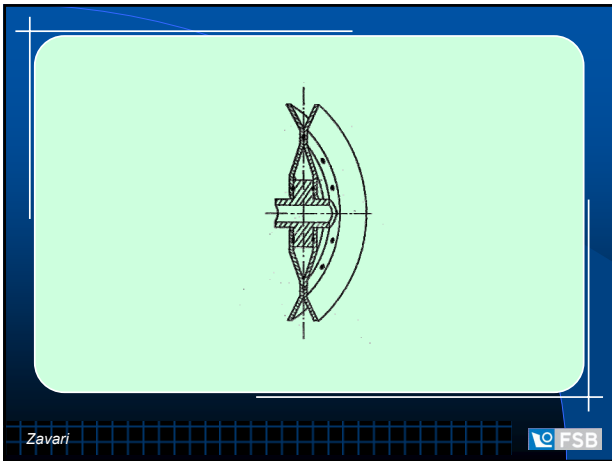

Zavarivanje pritiskom

Redni broj	Naziv	Simbol	Priprema	Izvedba
1	Zavar s odebljanjem	I		
2	Zavar sa srhom	⊥		

Zavari

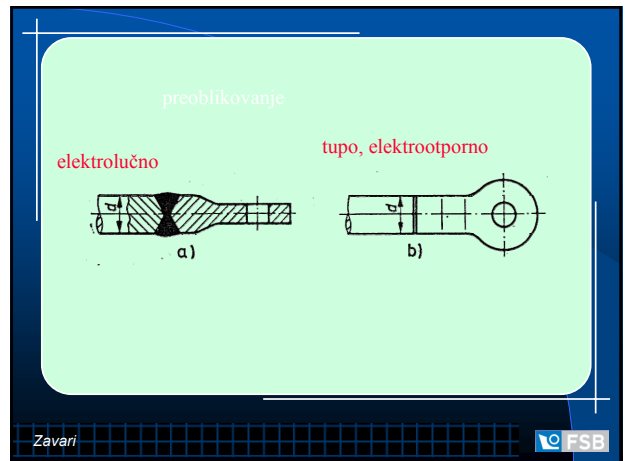
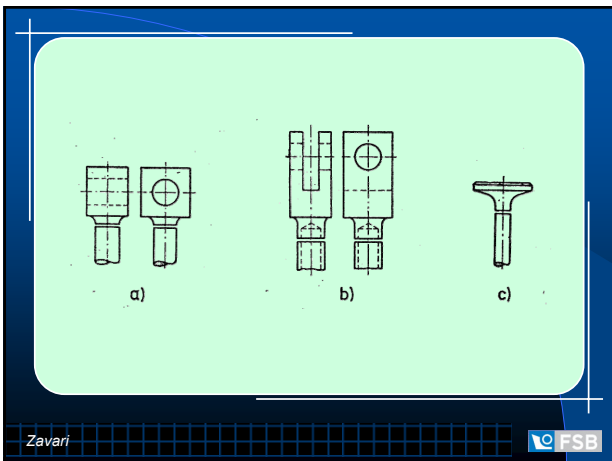
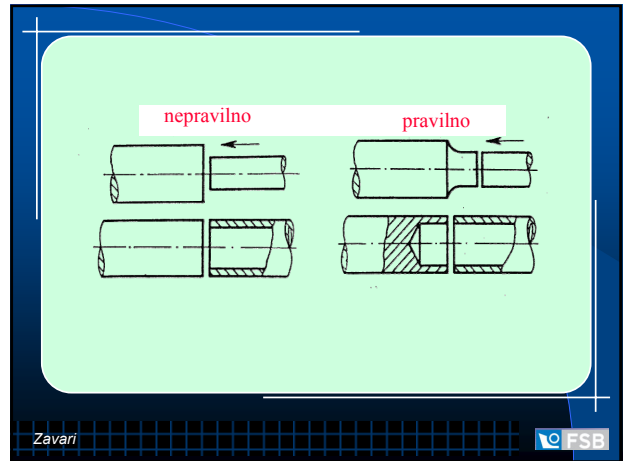

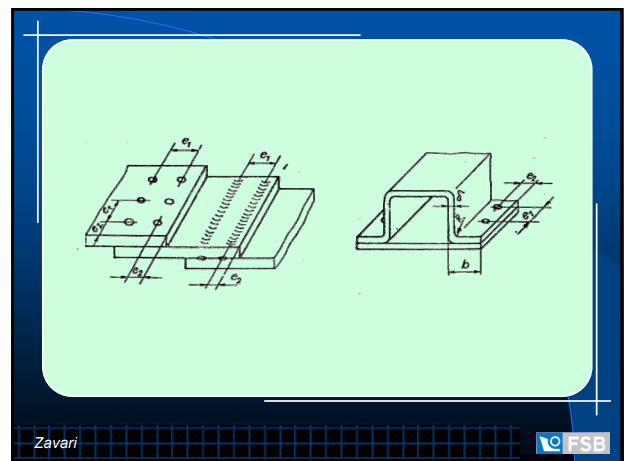
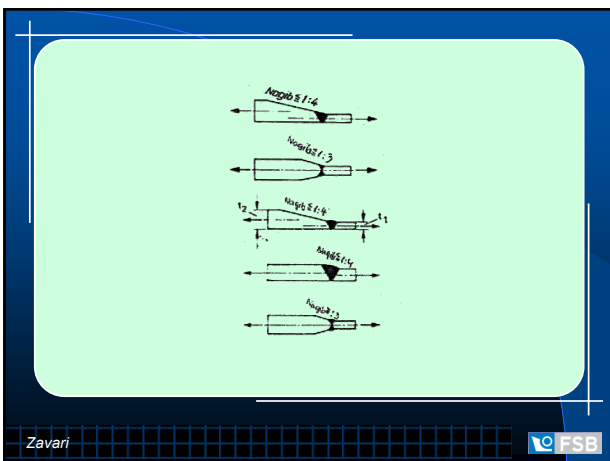
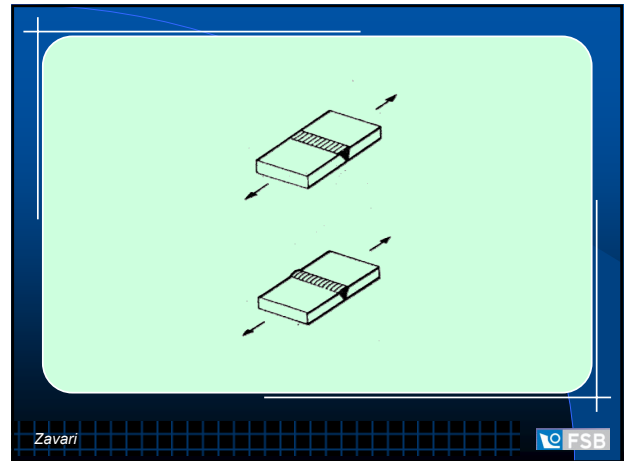
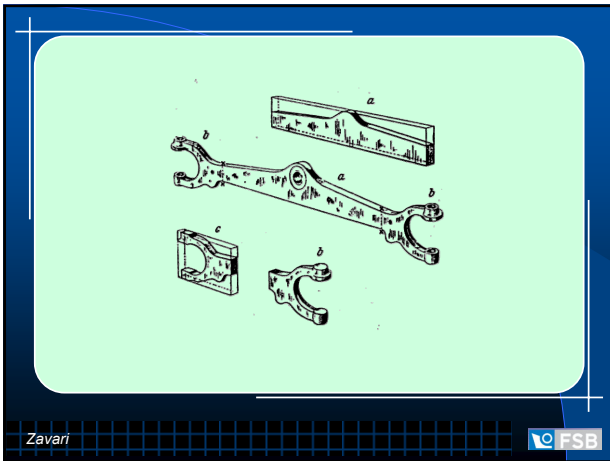
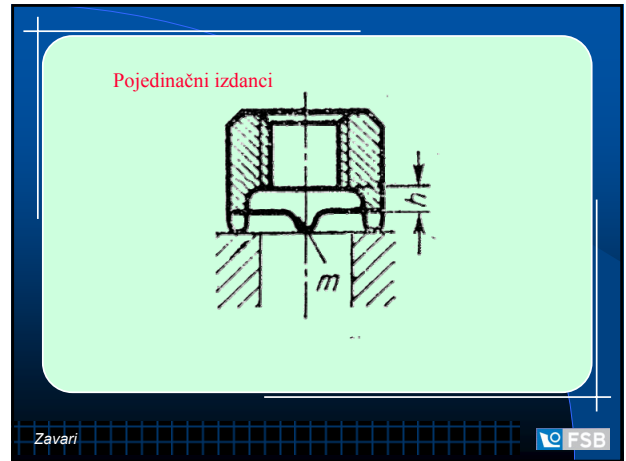
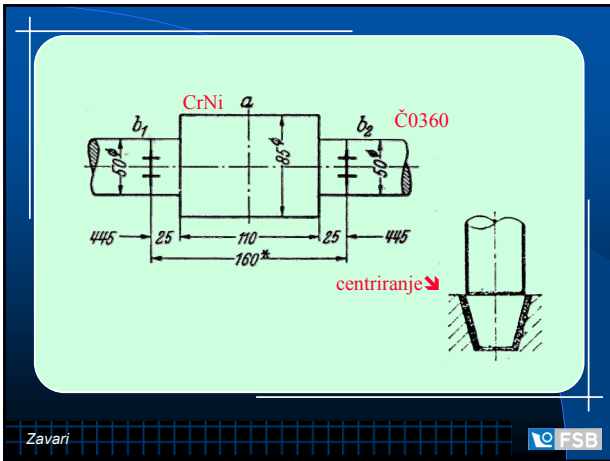

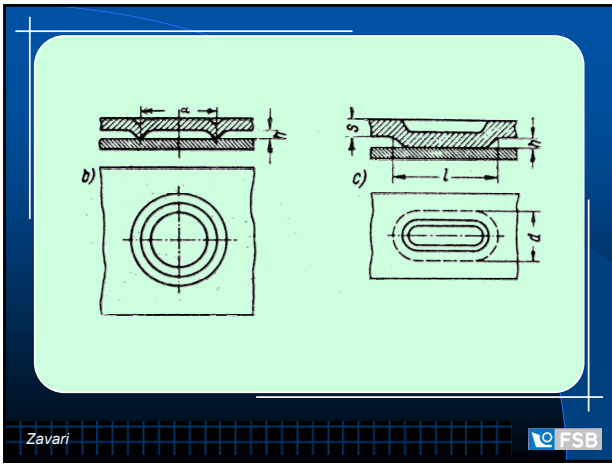

Zavari

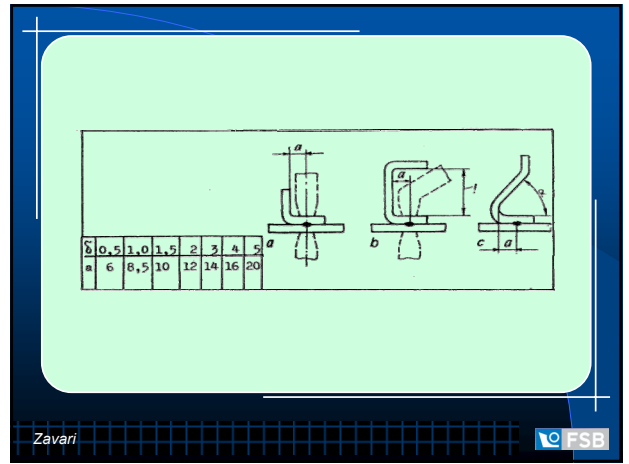

Zavari

